

MONO

FULLY OPTIMIZED &
AUTOMATED
PROCESSES WITH
THE BEST
FLEXIBILITY & EFFICIENCY

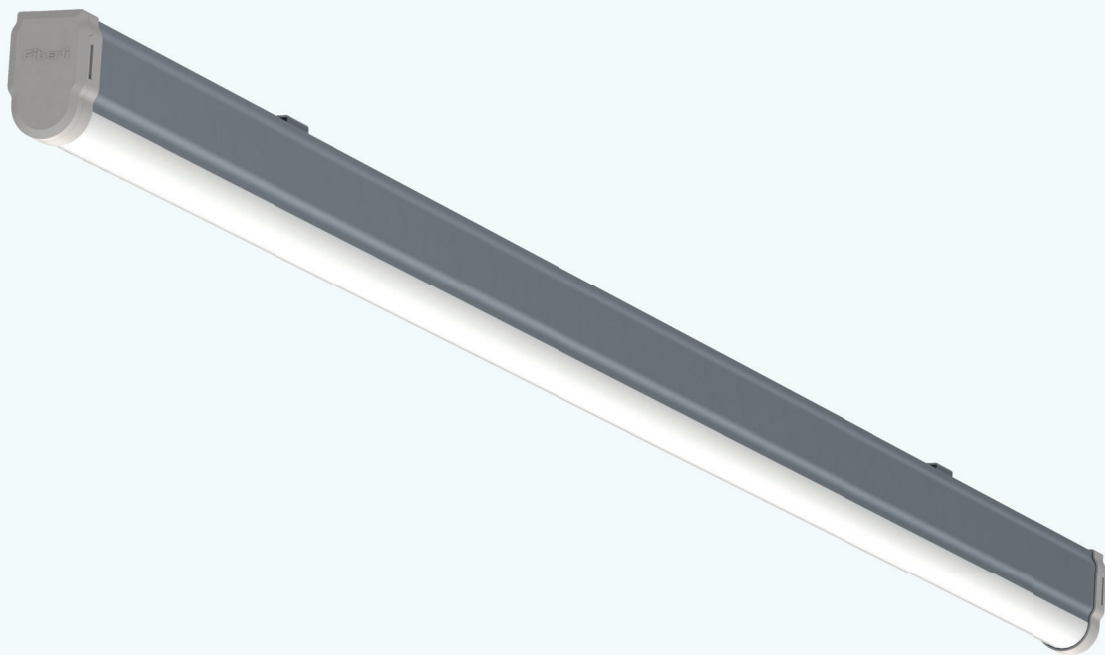

A REAL SUPERHERO MEMBER OF GROWLIGHT FAMILY.

Mono. Future of farming. Thanks to its slim design and flexibility, MONO is perfectly suitable for climate-controlled cultivation facilities, such as city/vertical farms, propagation and research centers that use multilayer rack systems. Also provides cost effective solution due to its high energy efficiency and long-life structure. Controllable, easy to mount, automation ready, flexible spectrum on request GROWLIGHT solution. Expanding options with special body design.



A better way to see!

ELECTROMECHANIC SPECIFICATIONS

Voltage	108-305 AC 50-60Hz
Watt	36W
Amps at 220V	3 A
Max Ambient temp	-30° +50°
Power factor (cosØ)	>0.95
Power connection	Standart 40cm cable, IP66 socket (optional)
Dim	0-10V or PWM (optional)
Weight	1 kg

DIMENSIONS

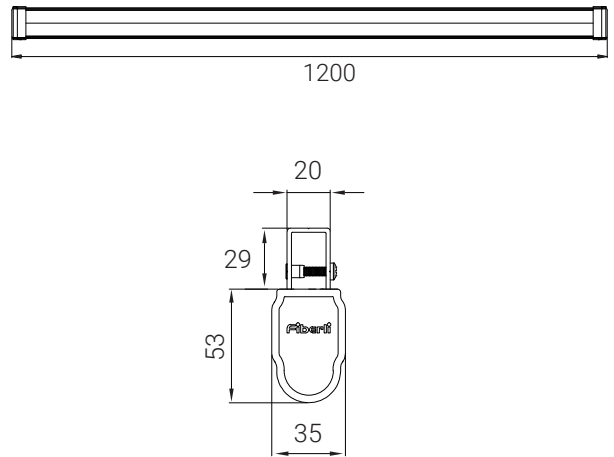

SPECTRUM

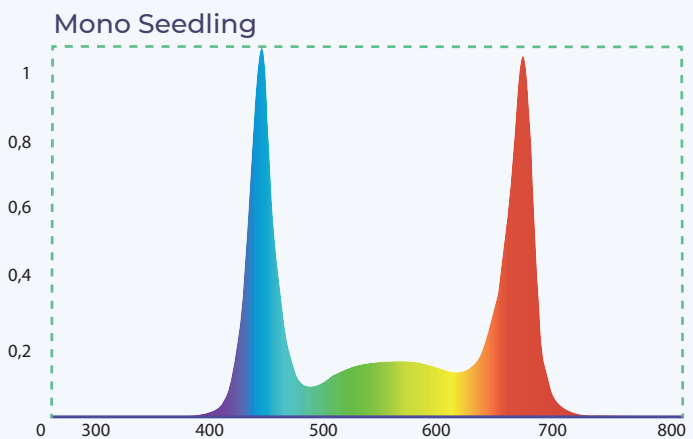
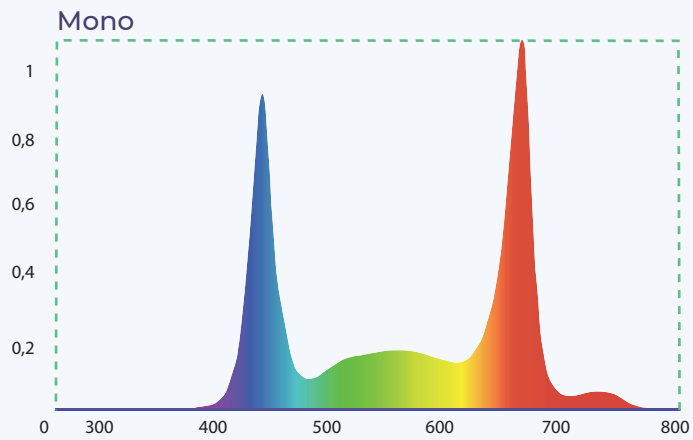

*Legal disclaimer – Fiberli LED grow lights for cannabis production are only sold to geographical territories where the growth of cannabis is legalized by local laws.